

**a guide to
HARDWOOD
LOG GRADING**

(Revised)

by **Everette D. Rast**
David L. Sonderman
Glenn L. Gammon

U.S.D.A. FOREST SERVICE GENERAL TECHNICAL REPORT NE-1
1973

Forest Service, U.S. Department of Agriculture
Northeastern Forest Experiment Station
370 Reed Road, Broomall, PA. 19008

a guide to **HARDWOOD LOG GRADING**

Abstract

A GUIDE TO HARDWOOD LOG GRADING (Revised) was developed as a teaching aid and field reference in grading hardwood logs. Outlines basic principles and gives detailed practical applications, with illustrations, in grading hardwood logs. Includes standards for various use classes.

The Authors

EVERETTE D. RAST received his bachelor of science degree in forestry from the University of Missouri in 1960 and his master of science degree in agricultural economics from Ohio State University in 1970. He joined the U.S. Forest Service in 1960 as a forester on the Mendocino National Forest and in 1966 transferred to the Northeastern Forest Experiment Station. He has served since that time as a research forest products technologist on the quality and grade of hardwood timber project at Columbus, Ohio.

DAVID L. SONDERMAN, research forest products technologist, received his bachelor of science degree in forestry from West Virginia University in 1962. He joined the Northeastern Forest Experiment Station in June 1962 and was formerly on the staff of the eastern softwood timber quality project until June 1972. He is presently with the Northeastern Station's project on quality and grade of hardwood timber at Columbus, Ohio.

GLENN L. GAMMON, a research forest products technologist, received his bachelor's degree in forestry from the University of Georgia, and his master's degree in wood technology from the University of New Hampshire. He joined the Central States Forest Experiment Station in 1963. He is presently on the staff of the Northeastern Station's hardwood timber quality project at Columbus, Ohio.

CONTENTS

THE HARDWOOD TIMBER RESOURCE	1
LOG GRADES IN GENERAL	2
Objectives of log grading	2
Poorest Log Concept	2
Hardwood log use classes	4
Other products	7
Grade defects and scalable defects	7
DEFINITION AND APPLICATION OF SPECIFICATIONS FOR HARDWOOD LOG CLASSES AND GRADES	9
Hardwood veneer-log class	9
Forest Service standard grades for hardwood factory-lumber logs	11
Special instructions for factory logs	16
Surface features	16
End features	18
Construction-log class (Ties and heavy timbers)	20
Hardwood local-use log class	23
General grading procedures	24
Scaling	24
Relation of scaling deductions to log-grading defects ...	26
HARDWOOD TREE GRADES FOR FACTORY LUMBER	27
SELECTED REFERENCES	27
APPENDIX	
I. How to use log-grade information to establish log values	29
Factory-lumber logs	29
II. Tables for making interior scale deductions	30

The Hardwood Timber Resource

OF THE 2 trillion board feet of merchantable timber standing on forest lands of the United States, about one-fifth—400 billion board feet—is hardwood. One hundred fifteen commercial species produce sawed products; 74 of these same species also produce veneer.

These commercial hardwood species grow on half of the nearly 483 million acres of commercial forest land in the country and they produce one-fourth of all the lumber cut. The annual harvest of hardwood trees for lumber and other wood products amounts to about 12.3 billion board feet.

Fabricating this raw material into finished consumer goods is a complex business. Hardwoods vary greatly in their intrinsic qualities, both within and between species. Some, like yellow birch, cherry, persimmon, and walnut, have highly desirable qualities that put them almost in the class of precious woods. Others, like beech, boxelder, and scarlet oak, have qualities that make them much less desirable, so that there is usually less demand for them. The wide distribution and variety of species, together with these great variations in attributes in and between species and the intricacies of utilization, create both technical and economic problems in evaluating a species' utility.

Log Grades in General

OBJECTIVES OF LOG GRADING

A major objective of log classification is to separate from woods-run logs those that are suitable for the manufacture of a given product or class of products (veneer, standard lumber, ties, etc.) and, for each kind or class so separated, to determine the relative qualities of products obtainable from grades of logs with common surface characteristics. Other objectives are to establish basic specifications for log merchantability, to guide manufacturing processes and methods, to increase the efficiency of sampling for various forestry purposes, and to provide the basis for tree grades.

Some people judge usefulness of a log-grading system by simplicity or ease of application. This is not a sound approach. *Whether log grades are suitable for a given objective depends not upon how easy they are to use but upon how well they meet stated performance standards.* In the task force report prepared for the Forest Service Log Grade Committee (10), the objectives and the application of standards are discussed in considerable detail. For example, in the hardwood factory-lumber log grades, the Forest Service standards require that the system must:

1. Separate from woods-run logs those that are logically suited for sawing into standard factory lumber.

2. Segregate such logs into high-, medium-, and low-quality groups (grades) determined by the lumber-grade yield pattern and gross lumber value they will produce when sawed into lumber in an adequate mill by a sawyer skilled in the production of standard graded hardwood lumber.

3. Provide a substantial differential in average lumber value between the several log grades, and minimize the overlapping of values of individual logs in the different grades (as

when a low-grade log cuts out better than a log of equal size in a higher grade).

4. Perform on small numbers of logs (say 25 to 50 logs) as well as on larger numbers.

5. Use terms and methods sufficiently objective so that men with a reasonable amount of training and experience can apply them in a practical way to a wide range of activities (timber appraisal, timber management, log sale or purchase, production control, or research).

POOREST LOG CONCEPT

Any system for grading raw material must provide a floor: a limit below which the material is not acceptable for conversion. Thus, a *poorest log* is specifically described even though it is recognized that its specifications may vary from time to time with changing economic conditions. If material below this arbitrary minimum is utilized, it becomes merely another group of bole segments, usually of minor significance, which can be evaluated separately. When the use does not include everything down to the poorest log, as defined, the minimum can be raised to the next higher standard classification.

A practical definition for a standard minimum hardwood log is: Any piece of a tree stem 8 inches or more in diameter and 8 feet or more in length, with sweep not exceeding one-half the diameter of the small end; with not more than two-thirds the gross volume in scalable defect; and with any number of knots, holes, rotten areas, etc.—provided the diameter of none exceeds one-half the diameter of the log at point of occurrence. A log is separated from a bolt by a length specification: bole segments 8 feet or more in length are called logs; those under 8 feet are generally called bolts. The potentially usable material in a hardwood tree is illustrated in figure 1.

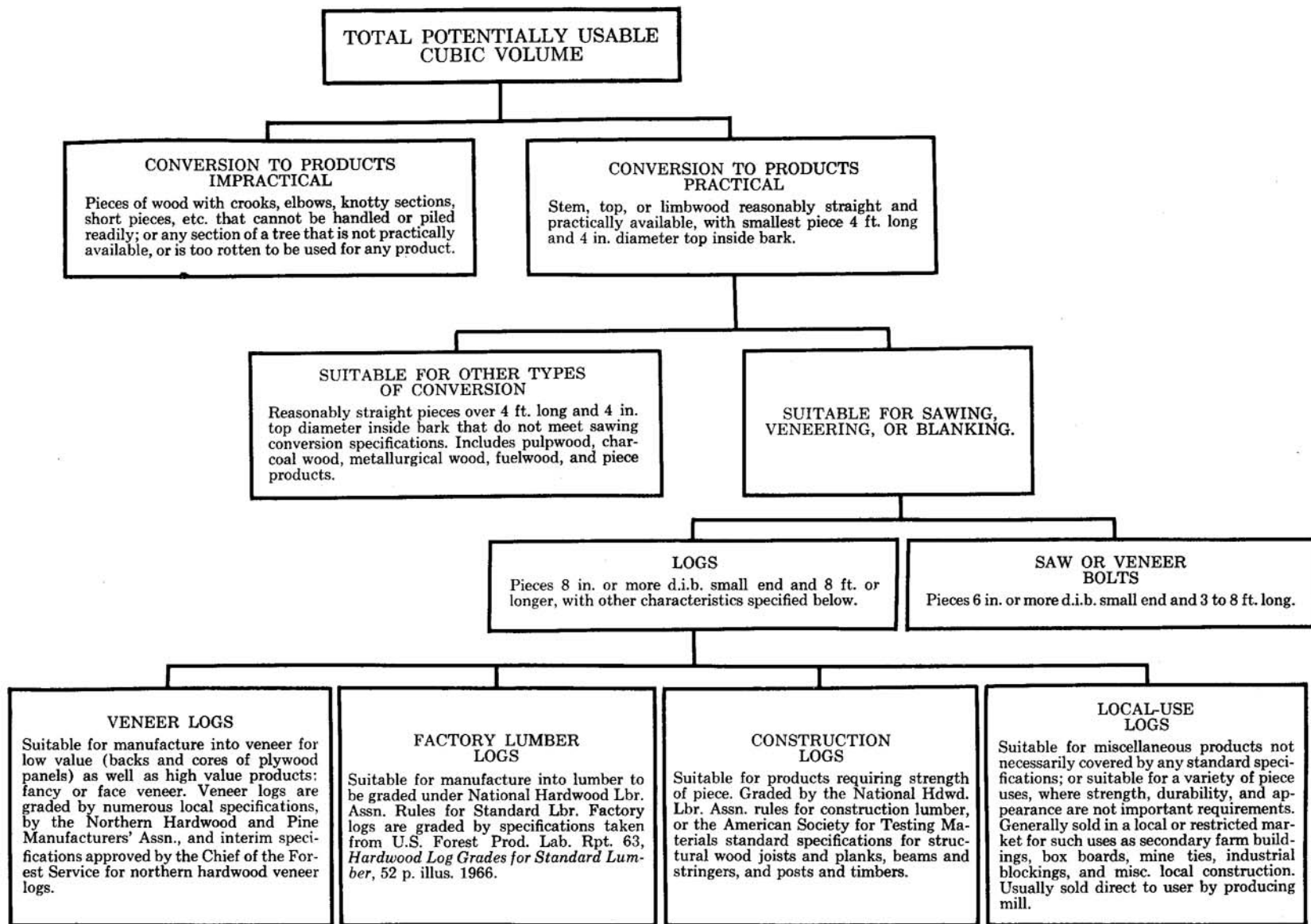

Figure 1.—The possible products obtainable from the total cubic volume in a hardwood tree.

HARDWOOD LOG USE CLASSES

The many factors that influence log quality can be isolated and their effect gaged only if use is taken into consideration. Not all hardwood logs that exceed the minimum specifications are equally suitable for all products, even though the quality requirements may be similar. However, four log-use classes are enough to cover current hardwood utilization practices. They are as follows:

1. *Veneer Class.*—This class includes the very high value logs as well as some relatively low value logs. Many logs that qualify for factory-lumber grades 1, 2, and 3 can also be utilized as veneer logs.

Interim specifications for northern hardwood veneer logs (birch, beech, maple, and cherry) were approved by the Chief of the Forest Service in March 1964 for use in timber appraisals in Region 9 and that part of Region 8 that is in the southern Appalachian Mountains.

2. *Factory Class.*—This type of log is adapted to the production of boards that later can be remanufactured so as to remove all defects and obtain the best yields of clear face and sound cuttings.

The grade of lumber cut from such logs is determined by specifications of the National Hardwood Lumber Association grading rules for standard lumber (fig. 2) (9). These grades specify the minimum yield of defect-free material from boards in each grade. High-grade boards are those that will yield high percentages of clear face cuttings in relatively large sizes. Low-grade boards are those that yield small percentages of clear face and sound cuttings.

3. *Construction Class.*—This class includes logs suitable for sawing into ties, timbers, and other items to be used in one piece for structural purposes. Grade specifications are contained in the construction-lumber section of the National Hardwood Lumber Association rules; the tie specifications of the American Railway Association (1); and the standard specifications for structural wood joists and planks, beams and stringers, and posts and timbers of the American Society for Testing Materials.

In general, these specifications are designed to insure the strength of the piece. In the usual run of logs suitable for this use, position and condition of the heart center are especially important. Knots and other defects that would impair the strength of the product are limited to sizes that hold the impairment within acceptable limits.

Although factory-lumber grades allow more defects in the lower grades, construction lumber specifications prohibit weakening imperfections equally in all grades. This results in log requirements different from those for factory-lumber use. For example, a factory log with a rotten, shaky interior, and having large but widely spaced surface defects may produce enough high-grade boards to yield a high average quality. Yet such a log would be practically worthless as a construction log (see figure 8, fourth illustration).

4. *Local-use Class.*—In general, local-use logs are those that are suitable for products not usually covered by standard specifications. High strength, great durability, or fine appearance are not required for the following types of products: crating, pallet parts, mine timbers, industrial blocking, secondary farm buildings, etc. Whereas the other three classes are usually sold over a wide area and through a variety of marketing channels, local-use materials are generally sold directly to the user by the producer. This often makes local-use logs rather profitable.

Within the veneer, construction, and local use classes we may need further separation by grades. The grade specifications are designed to separate logs into value groups based on product requirements. There is no implied price relationship between any grade in one class and any grade in another class. There may be no basic price distinction between classes. The value of the products in the various classes, and of the grades from which they can be made, depend upon the processing equipment and operating methods of the operator. For example, a mill that converts construction-class logs has an entirely different value basis from a mill processing factory-lumber logs. The local-use class usually has the least value, but this does not mean that logs in this class are unprofitable.

Figure 2.—Basic grade specifications for hardwood lumber.^a

Grade	Minimum Specifications				
	Length ^b (feet)	Width (inches)	Yield of rough lumber in clear cuttings ^c (percent)	Size of cuttings	Cuttings ^d (number)
Firsts & seconds	8	6	83 1/3	4" x 5' or 3" x 7'	1 to 4
Selects	6	4	Better face is seconds; reverse side of cutting is sound, or reverse side of piece is 1 Common.		
1 Common	4	3	66 2/3	4" x 2' or 3" x 3'	1 to 5
2 Common	4	3	50	3" x 2'	1 to 7
Sound wormy	Full log yield of 1 Common and better, with worm holes, knots, etc. not over 3/4 inch; stain admitted into cuttings.				
3A Common	4	3	33 1/3	3" x 2'	No limit
3B Common	4	3	25 ^e	1 1/2" & containing not less than 36 sq. in.	No limit

^a The basic grade specifications for hardwood lumber were adapted from the rule book of the National Hardwood Lumber Association (Chicago, Jan. 1971-Jan. 1975) pp. 17-23.

^b Percentage of short lengths is limited by grades: for example in First only 12 percent can be 8 feet to 9 feet; in 2C, 10 percent can be 4 feet to 5 feet.

^c A. *Clear face cutting*: A cutting having one clear face (ordinary season checks admitted) and the reverse side sound as defined in "sound cuttings." The clear face of the cutting shall be on the poor side of the board except when otherwise specified. Admissible defects: ordinary season checks, unlimited sapwood, mineral streaks and spots, burls, and stain provided it will dress out.

B. *Sound cuttings*: A cutting free from rot, pith, shake, and wane. Texture is not considered. It will admit sound knots, bird pecks, stain, streaks or their equivalent, season checks not materially impairing the strength of the cutting, pin, shot, and spot worm holes. Other holes 1/4" or larger are admitted but shall be limited as follows: One 1/4" in average diameter in each cutting of less than 12 units; two 1/4" or one 1/2" to each 12 units and on one side only of a cutting.

^d Number varies with surface measure of piece; for example, in 1C with surface measure of 5 feet to 7 feet, two cuttings are allowed; in 1C with surface measure of 11 feet to 13 feet, four cuttings are allowed.

^e On basis of sound cuttings; lumber is suitable for low-grade crating and dunnage.

The comparative values, as illustrated in figure 3, provide the log grader with the basic information for choosing the best possible grading system that reflects the business situation for which grading is to be the control. The values for veneer are log values, whereas those of the other three classes are lumber values, because the prices of piece veneer would be unrealistic in relation to lumber prices.

For example, at a standard lumber mill first grading choice is the factory-lumber class. However, at many lumber mills the veneer class logs will be withdrawn first for shipment to a hardwood veneer and plywood plant. After the grader has selected the logs that meet the specifications for factory grades 1, 2, and 3, (F1, F2, F3) he will, in all probability, be left with a residue of lower quality logs. Either he does not grade these, considering

Figure 3.—Range of product values for major use classes of logs.

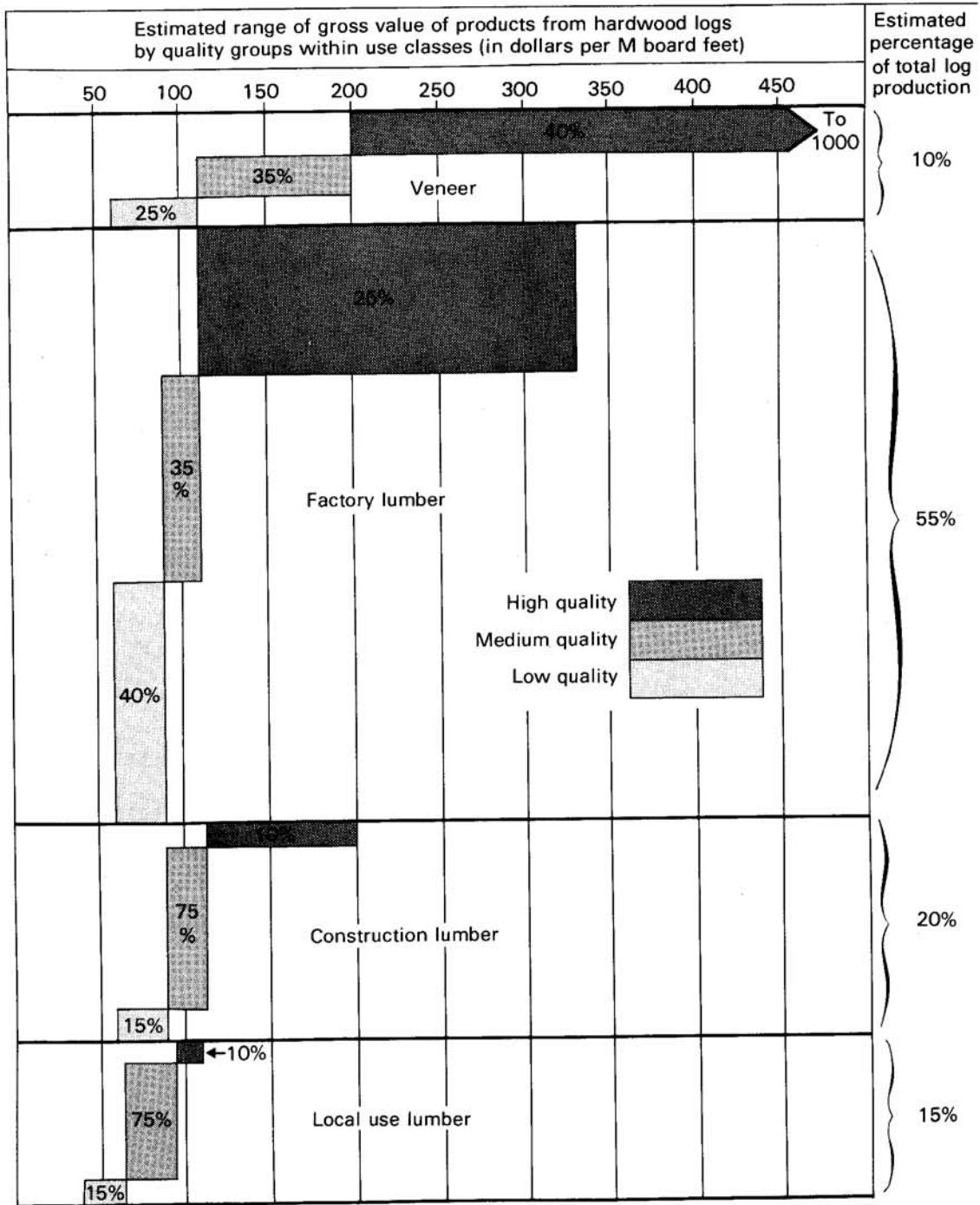

Note: Height of vertical bar distances represents proportion of log volumes.

RANGE OF PRODUCT VALUE PER M*

Use Class	High-Quality Logs	Medium-Quality Logs	Low-Quality Logs	All Logs
Veneer logs	200-1000	115-200	65-115	320
Factory lumber	110- 330	90-110	60- 90	120
Construction lumber	115- 200	90-115	60- 90	105
Local Use lumber	95- 110	65- 95	40- 65	80

* Values for veneer are log values; all others are lumber values.

them all merely sub-grade logs; or he sorts out the logs that will make the next most valuable class, construction lumber. Any further residue then falls into the local-use class—provided, of course, that they meet the minimum specifications.

This method of grading is a one way street, for logs not suitable for the first classification may be suitable for a lower class.

OTHER PRODUCTS

So far, we have been concerned primarily with veneer, lumber, and timbers, and it may seem that inadequate attention has been given to other products such as cooperage, dimension stock, handle stock and specialties. However, multi-product logging has already recognized the need for sorting out the numerous products, including pulp. These items do assume considerable importance locally, and account for about 25 percent of total hardwood utilization. Specialty product specifications are related closely to those for factory lumber because relatively short, clear pieces of practically defect-free wood are required. Limited studies of specialty products have shown that log quality for specialty products can be gaged closely by the hardwood factory-lumber log grading system or modifications thereof.

GRADE DEFECTS AND SCALABLE DEFECTS

The Society of American Foresters in its *Forestry Terminology* defines the term *defect* very broadly as “any irregularity or imperfection in a tree, log, piece product, or lumber that reduces the volume of sound wood or lowers its durability, strength, or utility values.”

Defects fall into two main categories: (1) those that reduce the volume of sound wood or lower its durability; and (2) those that lower its strength, take away from its appearance, or otherwise limit its utility. The first are *scalable defects* (rot, shake, etc.). The second are *grading defects* (knots, stain, etc.).

The term *defective timber* popularly con-

notes rotten or over-mature trees, but such trees may contain much usable material. The amount of scalable defect, together with size limitations, is often the main criterion of merchantability of logs or trees. Actually, logs from which *unusable material* (scalable defect) will be removed in manufacture are not necessarily defective in grading terms, for there may be no grade defects in the remaining usable wood.

On the other hand, perfectly sound trees (without scalable defect) may be worthless because of grade defects that cannot be eliminated in manufacture. The distinction between scalable defects and grade defects is not always clear-cut. Small volumes of scalable defect may be left in the product, affecting strength or utility or lowering product grade by detracting its appearance; they then become grade defects.

Usage gives the term “grade defect” to abnormalities or irregularities on the log surface as well as to imperfections in the wood. These outside features are really indicators of imperfections in the underlying wood and could be termed “grade defect indicators.” For example, a branch stub is an indicator of a knot in the product to be sawed from the log. Nevertheless, because timber appraisers deal with logs or tree stems as such, and not as sawn products, this publication designates these surface features as log grade defects or degraders. On the other hand, imperfections in the wood are designated as product grade defects. Further discussion of this can be found in U. S. Department of Agriculture Handbook No. 244, *Grade Defects in Hardwood Timber and Logs* (7).

The importance of use class in grading becomes apparent when log grade defects are considered. In one use class a certain irregularity or imperfection in the wood is a product grade defect, so the defect indicator on the log surface is a log grade defect. In another use class, the same irregularity or imperfection does not degrade the product, so the defect indicator on the log surface is not a log grade defect. An example of this is a ¼-inch sound knot. In factory lumber this is a product grade defect; in construction logs it is not (table 1).

Table 1.—Classification of log surface abnormalities

Abnormalities	Factory Logs	Construction Logs	Local-Use Logs
<i>Log surface</i>			
Bulges:			
Butt	Defect	Defect	No defect
Stem	Defect	Defect	No defect
Bumps:			
High	Defect	(3)	(3)
Medium	Defect	(3)	(3)
Low	(2)	(3)	(3)
Burl	Defect	Defect	(3)
Butt scar	Defect	(3)	No defect
Butt swell	No defect	(3)	(3)
Canker	Defect	Defect	No defect
Conk	Defect	Defect	No defect
Dormant buds	(2)	No defect	No defect
Epicormic branches	(2)	No defect	No defect
Flanges	No defect	No defect	No defect
Flutes	(3)	(3)	No defect
Fork	Defect	Defect	No defect
Gum lesions	(3)	No defect	No defect
Holes:			
Large	Defect	(3)	(3)
Medium:			
Bark scarrer, fresh	No defect	No defect	No defect
Bark scarrer, old	Defect	No defect	No defect
Birds, light	No defect	No defect	No defect
Birds, heavy	Defect	No defect	No defect
Grub	(2)	No defect	No defect
Increment borer	Defect	No defect	No defect
Tap	Defect	No defect	No defect
Small	(3)	No defect	No defect
Log knots:			
Sound	Defect	(3)	(3)
Unsound	Defect	(3)	(3)
Limbs	Defect	(3)	(3)
Overgrowths:			
Knots & bark pockets	Defect	(3)	No defect
Insects	Defect	No defect	No defect
Bird peck	Defect	No defect	No defect
Bark distortions:			
Heavy or medium	Defect	No defect	No defect
Light	No defect	No defect	No defect
Seams	(2)	(3)	No defect
Splits	(3)	(3)	No defect
Surface rise	No defect	No defect	No defect
Wounds:			
New	No defect	No defect	No defect
Old	(3)	(3)	No defect
<i>Log end</i>			
Bird peck	(2)	No defect	No defect
Bark pocket (crotch)	Defect	Defect	No defect
Double pith	No defect	Defect	No defect
Grease spots	(2)	No defect	No defect
Grub channels	(2)	(3)	No defect
Gum spots	(2)	No defect	No defect
Loose heart	(1)	Defect	No defect
Rot	(2)	Defect	No defect
Shake:			
Ring	(2)	Defect	No defect
Wind	(2)	Defect	No defect
Soak	(3)	No defect	No defect
Spider heart	(2)	Defect	No defect
Stain	(2)	No defect	No defect
Worm holes:			
Pin, flag & shot	Defect	No defect	No defect

- (1) Defect if not confined to heart center & inner quality zone.
(2) Refer to Special Instructions for Factory Logs (page 16).
(3) Refer to Grade Defects in Hardwood Timber and Logs, Agr. Handbk. No. 244.

Definition and Application of Specifications for Hardwood Log Classes and Grades

HARDWOOD VENEER-LOG CLASS

The term *veneer* includes not only fancy or face veneer but also veneer suitable for the backs and cores of plywood panels and veneer for containers.

It has been commonly assumed that veneer logs must be of exceptionally high quality and that only a small proportion of factory grade sawlogs will qualify as veneer logs. Comparison of the Forest Service factory-lumber log grade specifications with the veneer-log specifications of the Northern Hardwood and Pine Association indicates that this assumption is incorrect. U.S. Forest Products Laboratory Research Paper FPL-13, *Changes in Mill Run Hardwood Sawlog Lumber Grade Yields When Veneer Logs Are Withdrawn* (12), shows that a varying proportion of both grade 1 and grade 2 factory lumber logs will qualify as veneer logs. The material for backs and cores of plywood panels and veneer for containers definitely allows the small sound defects generally permitted in the cuttings of the lower common grades of factory lumber. Logs suitable for these lower classes of veneer are often found among grade 3 factory-lumber logs.

At present there is no standard system for grading veneer logs that is based on research. However, there are numerous local grade specifications, such as those published by the Northern Hardwood and Pine Manufacturers' Association and the American Walnut Manufacturers' Association. Because they are generally based on limited information about the factors influencing veneer-log quality, these systems could be improved. Studies made by the Forest Products Laboratory have provided the veneer grades necessary to develop such specifications for logs. These are contained in

Forest Products Laboratory Research Paper FPL-9, *Recommended Veneer Grades for the Development of Hardwood Veneer Log Grades* and Forest Products Laboratory Note 025, *Using the FPL Hardwood Veneer Grades*.

Late in 1963, the leader of the Hardwood Log Grade Project was authorized by the Washington Office, Division of Timber Management, to develop veneer-log specifications to be used in Forest Service timber sale appraisals. In cooperation with the regions involved, the project leader developed a set of interim specifications for northern hardwood veneer logs (fig. 4), recommended mainly for the northern hardwood species: beech, birch, maple, ash, and cherry. These were approved by the Chief of the Forest Service in March 1964 for use in timber appraisals in Region 9 and that part of Region 8 that is in the southern Appalachian Mountains.

These specifications are based on limited information about the factors that influence veneer-log quality, but they are definite and explicit enough to be applied directly. They should not be considered final, but merely a bridge between the present and the time when additional studies supply the data for developing standard veneer-log grades and accompanying veneer-grade yield tables.

The interim specifications clarify specific grading factors, and are quite similar to the Northern Hardwood and Pine Association specifications. Adventitious bud clusters and small branches (less than 1/2 inch) are disregarded because they will normally disappear in "rounding up" the log.

The specifications define use classes. They provide a sound basis for separating potentially fancy or face veneer quality material from factory-lumber logs, and they are applicable to both cut logs and standing trees.

Figure 4.—Northern Hardwood Veneer Log Specifications.^a

Grading Factors	Specifications
1. Length	8 feet and over plus 6 inches trim allowance. ^b
2. Diameter (minimum)	12 inches d.i.b.—small end. ^c
3. Sweep	¼ inch per foot of log length
4. Crook and/or catface	1 admitted in logs of all lengths and diameters if it can be contained in a 2-foot long scaling reduction from either end, or from within the log provided that a cutting at least 52 inches long remains on each side of the scaled out portion.
5. Spiral Grain (maximum)	½ inch per foot of log length
6. Crotch	Crotch admitted in logs of all diameters provided it can be cut off by deducting 1 foot of length in scaling.
7. Seam	None admitted which enter the right cylinder in logs 12, 13, and 14 inches d.i.b. Logs 15 inches d.i.b. and larger admit one seam, entering the right cylinder, provided that it diverges from a straight line between the log ends no more than ½ inch per foot of log length. Such a seam constitutes 1 standard defect.
8. <i>Standard Defect (other than seam)</i> Knots, worm holes, dead or rotten areas, high bumps (with height over length ratio greater than 1 to 6), heavy bark distortions and old bird pecks (4 or more per sq. ft.). ^d Treat any number as 1 standard defect when located not more than 10 inches from an end or so located that they can be included in a 1-foot reduction in log length when the log is scaled.	One standard defect admitted in logs 8 through 10 feet long, 2 in logs 12 feet and, 3 in logs 14 through 16 feet.
9. <i>End Defects</i> A. Black heart and/or mineral stain	Admitted in hard maple logs when not in excess of ½ the scaling diameter.
B. Hole, rot, ring shake, loose or spider heart, and heart checks	Admitted when confined to a central core around the geometric center of the log end and the last 2 feet of log length—subject to scaling reduction. ^d After scaling reduction: Logs 12, 13, and 14 inches d.i.b. can contain central core with long axis no longer than 3 inches; logs 15 inches d.i.b. can contain central core with long axis no longer than 4 inches; and logs 16 inches and over d.i.b. can contain central core with long axis no longer than 6 inches.
C. Knots, partial ring shake, worm holes, bird pecks, stain spots, incipient rot areas, and bark pockets	Admitted to all logs outside the central core (9B) when confined to a ¼ segment of one end. When occurring on both log ends, must be confined to same ¼ segment in logs 12 through 15 inches d.i.b., can be in different ¼ segments in logs 16 inches d.i.b. and larger.

^a Recommended mainly for northern hardwood species of beech, birch, maple and cherry.

^b 7-foot lengths are accepted by most mills; 6 foot lengths are accepted by most mills for black walnut.

^c Select Veneer Grade—Logs 14 inches and over d.i.b.—must be free of all defect except for the allowable unsound central core (9B) and sweep (3).

^d Logs subject to 2 foot scaling reduction in length due to unsound central core (9B) permit unlimited surface defects over the 2 feet so treated (8).

**FOREST SERVICE STANDARD
GRADES FOR HARDWOOD
FACTORY-LUMBER LOGS**

The factory-lumber log class has been divided into three grades. The specifications for these grades (fig. 5) are closely correlated with the specifications for standard hardwood lumber grades, the grade of the log depending largely on the proportion of log length that is obtainable in clear cuttings (table 2).

The major factors that affect the quality of factory-lumber logs are: (1) position of log in tree (butt or upper); (2) size of log, especially diameter; (3) straightness; (4) amount and distribution of scalable defects; and (5)

Table 2.—Minimum length of clear cuttings by log length and proportion required

Log Length (feet)	5/6	3/4	2/3	1/2
	<i>Feet and inches</i>			
8	6' 8"	6' 0"	5' 4"	4' 0"
9	7' 6"	6' 9"	6' 0"	4' 6"
10	8' 4"	7' 6"	6' 8"	5' 0"
11	9' 2"	8' 3"	7' 4"	5' 6"
12	10' 0"	9' 0"	8' 0"	6' 0"
13	10' 10"	9' 9"	8' 8"	6' 6"
14	11' 8"	10' 6"	9' 4"	7' 0"
15	12' 6"	11' 3"	10' 0"	7' 6"
16	13' 4"	12' 0"	10' 8"	8' 0"

Figure 5.—Forest Service standard grades for hardwood factory lumber logs.^a

Grading Factors		Log grades							
		F1			F2			F3	
Position in tree		Butts only	Butts & uppers		Butts & uppers			Butts & uppers	
Scaling diameter, inches		13-15 ^b	16-19	20+	11+ ^c	12+		8+	
Length without trim, feet		10+			10+	8-9	10-11	12+	8+
Required clear cuttings ^d of each of 3 best faces ^e	Min. length, feet	7	5	3	3	3	3	3	2
	Max. number	2	2	2	2	2	2	3	No limit
	Min. proportion of log length required in clear cutting	5/6	5/6	5/6	2/3	3/4	2/3	2/3	1/2
Maximum sweep & crook allowance	For logs with less than 1/4 of end in sound defects	15%			30%			50%	
	For logs with more than 1/4 of end in sound defects	10%			20%			35%	
Maximum scaling deduction		40% ^f			50% ^g			50%	
End defect:		See special instructions (page 18)							

^a From USDA Forest Service Research Paper FPL-63 (13).

^b Ash and basswood butts can be 12 inches if they otherwise meet requirements for small #1's.

^c Ten-inch logs of all species can be #2 if they otherwise meet requirements for small #1's.

^d A clear cutting is a portion of a face, extending the width of the face, that is free of defects.

^e A face is 1/4 of the surface of the log as divided lengthwise.

^f Otherwise #1 logs with 41-60% deductions can be #2.

^g Otherwise #2 logs with 51-60% deductions can be #3.

defects in the usable wood outside the heart center. *Heart center* is used in a restricted sense; it is a cylinder in the center of the log with a radius equal to one-fifth of the scaling diameter.

The Forest Service Standard Grades for Hardwood Factory Lumber Logs call for grading the three best faces. After taking into account the size and soundness of the log, the grader visually squares the log full length into four faces so oriented as to give the largest number of good faces. Each face is evaluated the same way a board would be evaluated, with the exception that rip and sound cuttings are not allowed; all cuttings must be clear and full width of face. The poorest face of the log is eliminated. The grade of the log is then determined by the poorest of the three remaining grading faces (fig. 6). In practice it is possible for a trained grader to pick out the controlling or grading face by a quick inspection only, and make the necessary measurements on this face.

The major problem in grading factory-lumber logs is to locate clear cuttings. This requires the proper evaluation of surface indicators of defects. Branch stubs and knot overgrowths are clearly evident, so they present no problem. But the grader usually needs some training and experience to detect and evaluate accurately other less obvious indicators.

Once the faces have been graded, the log ends must be examined for grade defect indicators that may not show on the log surface. These are provided for by special instructions for evaluating end defects (page 18) and by the general restriction on the percentage of scaling deduction allowed in each grade. Minimum diameter, minimum length, maximum allowable sweep, and position of the log in the tree are also important grading factors. Examples of the three factory-lumber log grades are shown in figures 7, 8, and 9.

Lumber grade yields will vary by species and diameter within log grades. The yield of No. 1 Common and Better lumber for factory

Figure 6.—Selecting the grading face.

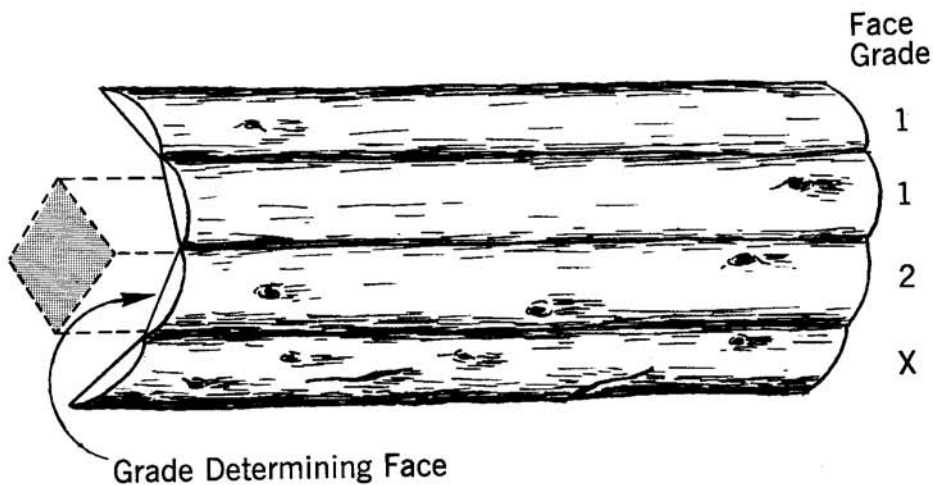
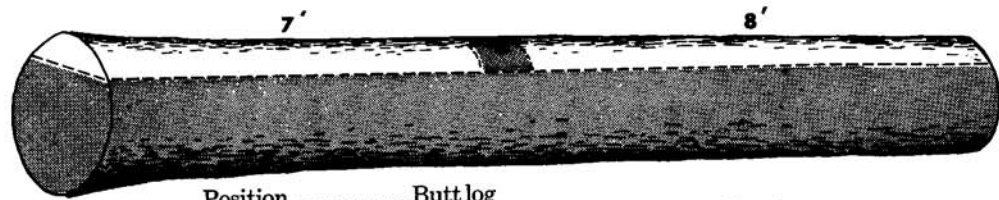
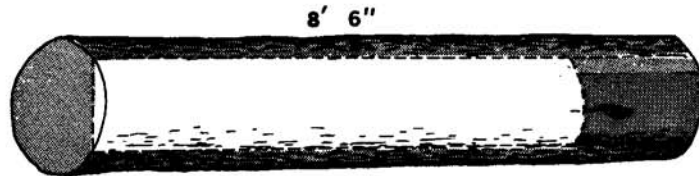

Figure 7.—Examples of hardwood factory grade 1 logs.



Position Butt log
 Size Length 16', diameter 13" at small end
 Straightness Straight
 Soundness Sound
 Cuttings More than 5/6 of its grading-face length is clear
 in two sections 7 and 8 feet long



Position Upper log
 Size Length 10', diameter 16" at small end
 Straightness Straight
 Soundness Sound
 Cuttings More than 5/6 of its grading-face length is clear
 in one section 8 feet 6 inches long

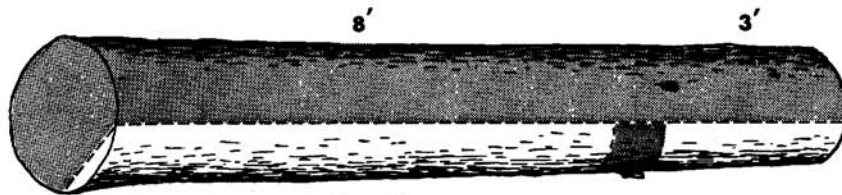

Position Upper log
 Size Length 12', diameter 20" at small end
 Straightness Straight
 Soundness Sound
 Cuttings 5/6 of its grading-face length is clear in two sec-
 tions 8 and 3 feet long

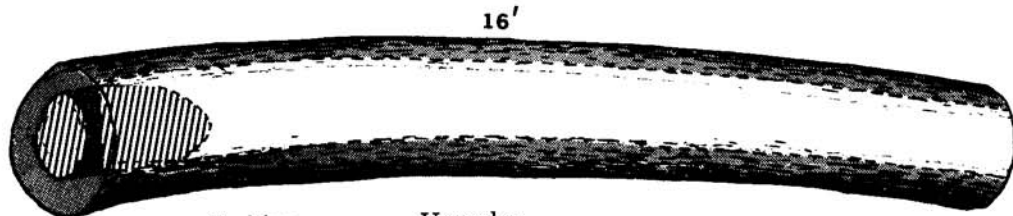

Position Upper log
 Size Length 16', diameter 20" at small end
 Straightness 10 percent deduction for 4" of absolute sweep
 Soundness 5 percent deduction for center rot (sweep and
 rot deductions less than 40 percent maximum
 permitted)
 Cuttings One cutting 16'
 Comments Rot is confined to permissible rot zone and does
 not affect clear grading face

Figure 8.—Examples of hardwood factory grade 2 logs.



Position Upper log
 Size Length 10', diameter 11" at small end
 Straightness Straight
 Soundness Sound
 Cuttings More than $\frac{2}{3}$ of its grading-face length is clear in two sections each 4 feet long

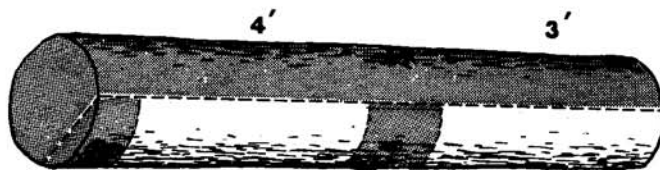

Position Upper log
 Size Length 9', diameter 12" at small end
 Straightness Straight
 Soundness Sound
 Cuttings More than $\frac{3}{4}$ of its grading-face length is clear in two sections 4 and 3 feet long

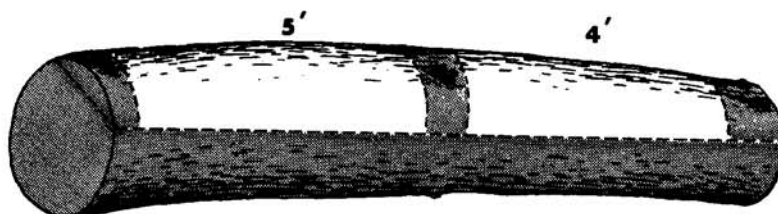

Position Upper log
 Size Length 11', diameter 18" at small end
 Straightness Deduction of 28 percent for 6½ inches of absolute sweep (sweep less than 30 percent maximum allowance)
 Soundness Sound
 Cuttings More than $\frac{2}{3}$ of its grading-face length is clear in two sections 5 and 4 feet long

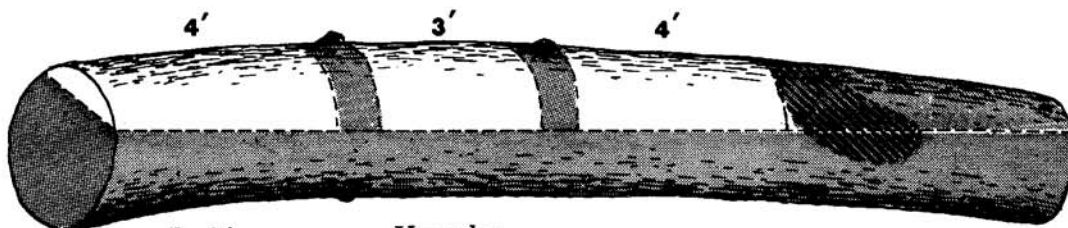

Position Upper log
 Size Length 16', diameter 22" at small end
 Straightness 9 percent deduction for 4 inches of absolute sweep
 Soundness 20 percent deduction for rot (sweep and rot deductions less than 50 percent maximum permitted)
 Cuttings Rot limits cutting on grading face, but clear cuttings of 4, 3, and 4 feet give more than the required $\frac{2}{3}$ of grading-face length

Figure 9.—Examples of hardwood factory grade 3 logs.

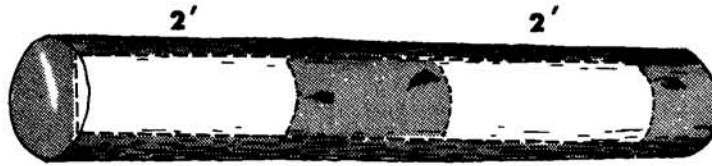

Position Upper log
 Size Length 8', diameter 8" at small end
 Straightness Straight
 Soundness Sound
 Cuttings One-half of its grading-face length is clear in two sections, each 2 feet long



Position Upper log
 Size Length 12', diameter 14" at small end
 Straightness Straight
 Soundness 15 percent rot deduction (less than 50 percent maximum permitted)
 Cuttings More than ½ of its grading-face length is clear in two sections, 4 and 3 feet long
 Comments Interior rot outside the rot zone limits cuttings



Position Upper log
 Size Length 14', diameter 22" at small end
 Straightness 12 percent deduction for 6" x 3' of crook on both ends of log
 Soundness 15 percent rot deduction (crook and rot less than 50 percent maximum deduction)
 Cuttings More than ½ of its grading-face length is clear in three sections, 3, 3, and 2 feet long



Position Upper log
 Size Length 16', diameter 22" at small end
 Straightness Straight
 Soundness Sound
 Cuttings More than ½ of its grading-face length is clear in two sections, 5 and 4 feet long

grade 1 logs will generally range from 65 percent upward; for factory grade 2 logs, from 40 to 64 percent; and for factory grade 3 logs, from 13 to 39 percent. Detailed grade-yield information is available in U. S. Forest Service Research Paper FPL-63 (13).

SPECIAL INSTRUCTIONS FOR FACTORY LOGS¹

Surface Features

Evaluation of defects.—A surface abnormality, if determined to extend into the log for a depth more than 15 percent of the diameter at the point of occurrence, is a log grade defect. Otherwise, it should be disregarded. All defect indicators judged to indicate log grade defects are counted as equal, with the following exceptions in factory logs only:

1. Epicormic branches:
 - a. Large (limbs more than $\frac{3}{8}$ inch diameter at origin or bark surface): full defect on logs of all sizes, grades, and species.
 - b. Small (limbs $\frac{3}{8}$ inch diameter or less):
 - (1) Hard hardwoods² (except black cherry, where they are not counted as defects): All grades: On logs less than 14 inches: full defect. On logs 14 inches and more: one-half defect; i.e., skip every other one.
 - (2) Soft hardwoods³: Grades 1 and 2: full defect on logs less than 14 inches; one-half defect on logs more than 14 inches. Grade 3: no defect.
2. Grub holes and grub-caused overgrowths:
 - a. Progressive on face.
 - (1) On logs 8-15 inches: each is a full defect.
 - (2) On logs 16-19 inches: disregard every sixth one.
 - (3) On logs 20-23 inches: disregard every fifth one.
 - (4) On logs 24-27 inches: disregard every fourth one.
3. Bumps: High and medium bumps must be considered on all logs, although in some species⁴ low bumps can sometimes be disregarded. Measurement of clear cuttings (fig. 10) is affected as follows:
 - a. High bump (length less than three times height: example—6 inches long and 4 inches high): Stop clear cutting at change in contour. Do not enter bump with clear cuttings.
 - b. Medium bump (length three to six times height: example—12 inches long and 2 to 4 inches high): Let clear cutting enter bump one-eighth of the length on each end.
 - c. Low bump (length 6 to 12 times height: example—12 inches long and 1 to 2 inches high): Let clear cutting enter bump one-fourth of the length on each end.
 - d. Surface rise (length more than 12 times height): disregard.
4. Straight seams, frost cracks, splits (fig. 11), extending into inner quality zone.
 - a. Straight seams extending all or part of the length of the log that can be considered as a line dividing two grading faces can be disregarded.
 - b. Straight seams not confinable to lines dividing grading faces.
 - (1) When full length of log: a full defect.
 - (2) When extending from one end of log towards middle: Include one-third of the seam length on interior end in the clear cutting.
 - (3) When completely in log: extend cuttings one-fourth of seam length from each end.
- (5) On logs 28 inches or more: disregard every third one.

¹ Based on USDA Agricultural Handbook #4 (8).

² Includes such species as sugar maple, beech, yellow birch, sycamore, hackberry, all oaks and ashes, and hickories.

³ Includes such species as soft maples, basswood, yellow-poplar, gum, magnolia, willow, cottonwood, and elm.

⁴ Includes such species as soft maple, tupelo, soft elm, birch, ashes, magnolias, and white oaks (white, cow, and swamp chestnut).

Figure 10.—Evaluation of bumps in hardwood factory lumber logs.

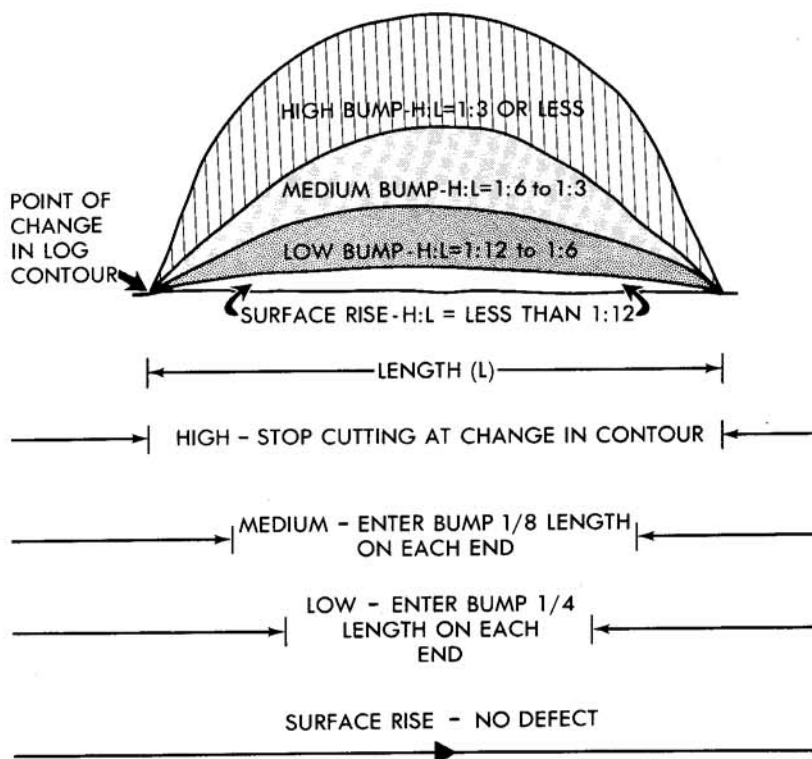
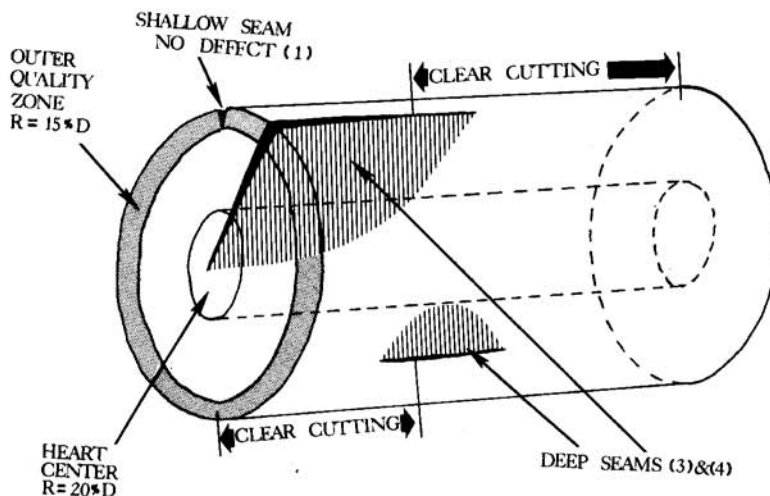

Figure 11.—Evaluation of seams, frost cracks, splits, etc., in hardwood factory lumber logs.



1. A seam, frost crack, split, etc. is not a defect unless it is deeper than 15% of log diameter.
2. No clear cuttings can be taken on a log face that includes a full-length straight seam or a spiral seam. However, one straight seam can be placed on the edge of one face and ignored. This fixes the location of all other defects.
3. A deep seam entering a face but not running full length may be overlaid with a clear cutting for one-third of its length, starting at the inner end.
4. When a deep seam is entirely within a log, clear cuttings can be laid over it from each end for a distance equal to one-fourth its full length.

5. Spiral seams, frost cracks, and splits, extending into inner quality zone: stop clear cutting where defect enters face being graded.
6. Bird peck. Individual pecks are not counted; length of pecked area is measured. A pecked area is one containing four or more pecks within 1 square foot.
 - a. Lightly pecked area (fewer than four pecks per square foot): disregard.
 - b. In grade 1 and 2 logs with four or more pecks per square foot:
 - (1) If pecks are open, disregard.
 - (2) If pecks are partially or completely occluded, the pecked area is a defect. (Note: age of peck does not matter; test is whether callus tissue is formed in the peck-holes.)
 - c. In grade 3 logs: disregard all pecked areas.

End Features

1. Definitions

- a. Heart center. Heart center is considered to be a core in the center of the log with a radius equal to one-fifth of diameter (fig. 12).
- b. Quality zone. The portion of the log outside the heart center (fig. 12).
 - (1) Inner quality zone—inside half of quality zone.
 - (2) Outer quality zone—outside half of quality zone.
- c. Affected area. This is defined as the area in which there are blemishes within 3 inches of each other. The total affected area, and not the area of the individual blemishes, is what determines the degrading effect.

Figure 12.—Location of end features in hardwood factory lumber logs.

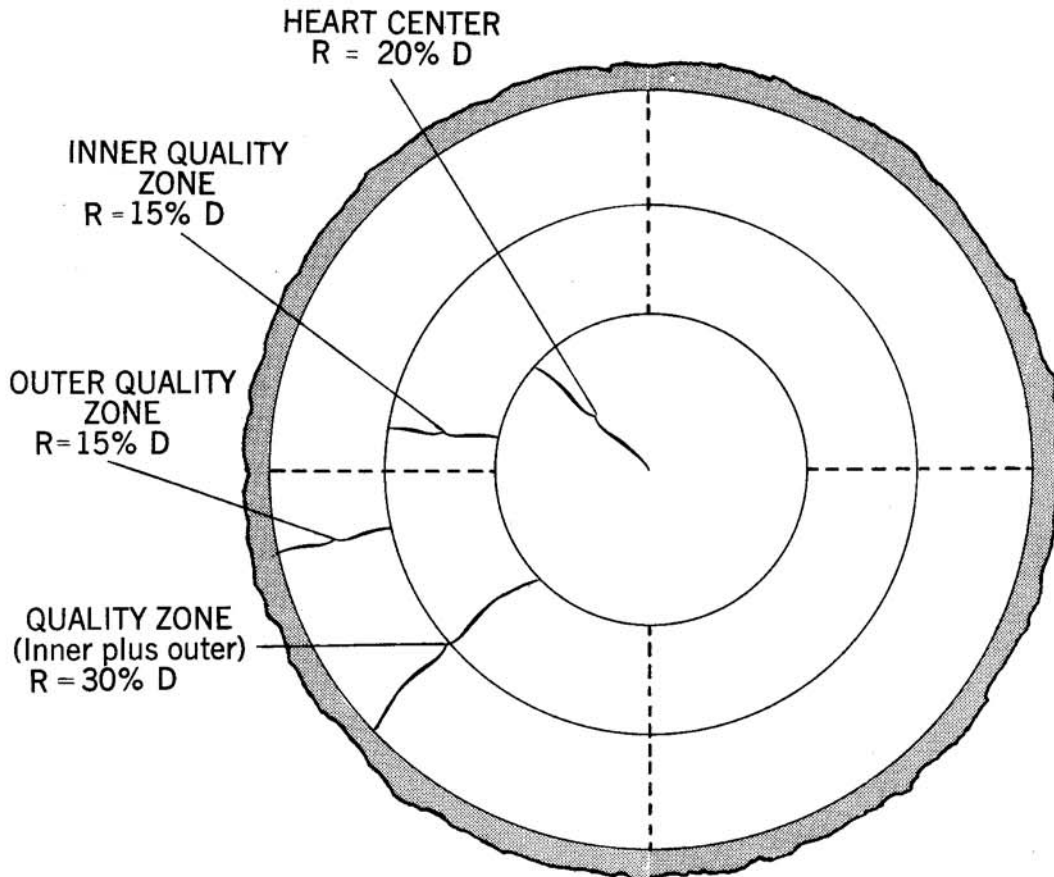

2. Evaluation

a. All abnormalities, regardless of type, can be disregarded in grading when they are confined to the heart center. However, they may cause scale deductions.

b. When an abnormality is not confined to the heart center, divide the log end into quarters conforming to the grading faces and evaluate as follows:

(1) Rot, heart check and ring shake (fig. 13). If these enter the quality zone in any quarter and are:

(a) Confined entirely within the inner or outer quality zone, make scale deductions as usual, but disregard as a log defect.

(b) In both inner and outer quality zones, make scale deductions as usual but consider as a defect in the quarter and face involved, as follows:

(i) If it extends full length of log, no clear cutting can be taken.

(ii) If it extends only partially through the log, allow cuttings to be measured back toward the log end one-third the length of the affected area from the point where it is estimated that the rot or shake tapers out.

(2) Spider heart. Defect if not confined to heart center.

(3) Spot worm holes, shot worm holes, pin worm holes, bird peck, bark pockets, grub holes, gum spots, grease spots. When enough of these are found to constitute an affected area in the quality zone and the radial measurement of this affected area is:

(a) In grade 1 and 2 logs:

(i) Less than half the radial width of quality zone: disregard.

(ii) Greater than half the radius of the quality zone in

Figure 13.—Evaluation of rot and shake in hardwood factory lumber logs.

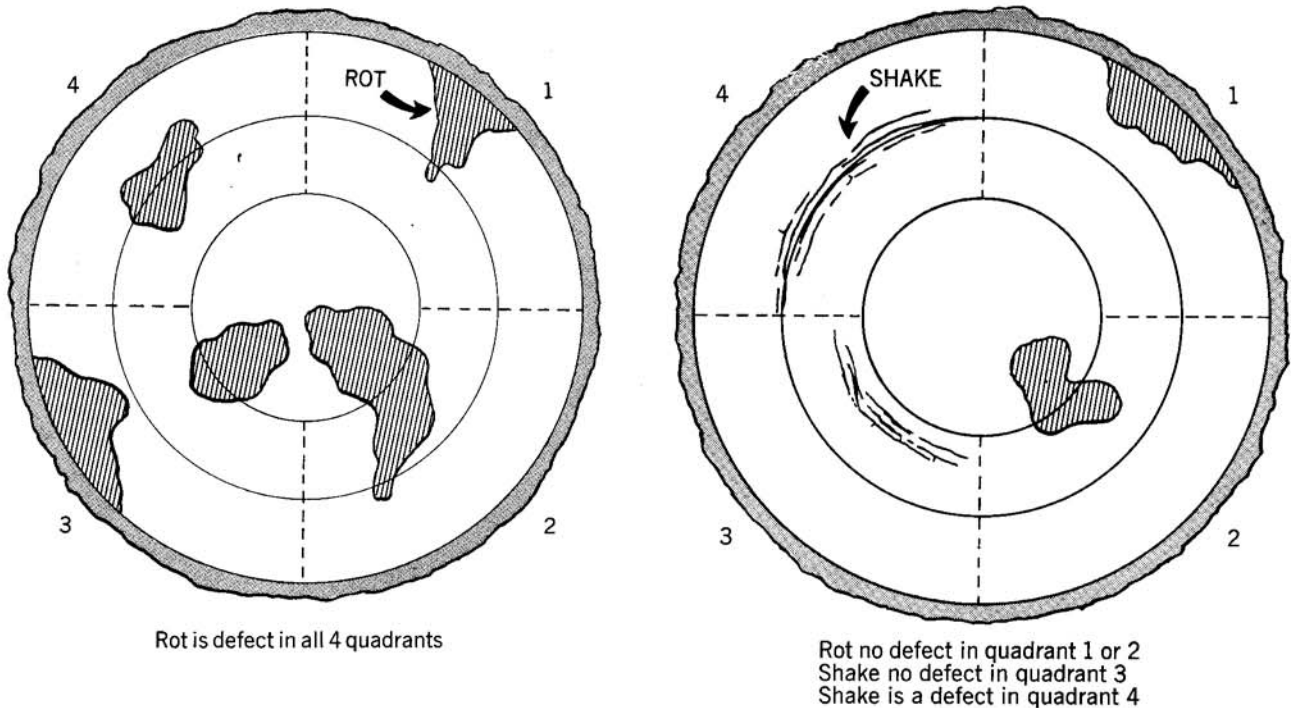

- three or more quarters on one end, or two or more quarters on both ends: de-grade one grade.
- (b) In grade 3 logs: disregard.
- (4) Stain. This is considered on the scaling end only; disregard if on the large end only. The affected area in this case is the total area involved, including the heart center. When stain occurs in several solid areas that are not joined, the extent is the sum of the individual areas. Treat as follows:

- (a) In grade 1 and 2 logs:
- (i) If diameter on scaling end is less than half the scaling log diameter, disregard.
- (ii) If diameter on scaling end is more, drop one grade.
- (b) For grade 3 logs: disregard.

CONSTRUCTION-LOG CLASS
(Ties and Heavy Timbers)

This class has not been divided into grades (fig. 14). The major factors that affect the quality of this class of logs are size and condi-

Figure 14.—Forest Service standard specifications for hardwood construction logs.^a

Position in tree		Butt & upper
Min. diameter, small end		8 inches +
Min. length, without trim		8 feet
Clear cuttings		No requirements.
Sweep allowance, absolute		$\frac{1}{4}$ diameter small end for each 8 feet of length.
Sound surface defects	Single knots	Any number, if no one knot has an average diameter above the callus in excess of $\frac{1}{3}$ of log diameter at point of occurrence.
	Whorled knots	Any number if sum of knot diameters above the callus does not exceed $\frac{1}{3}$ of log diameter at point of occurrence.
	Holes	Any number provided none has a diameter over $\frac{1}{3}$ of log diameter at point of occurrence, and none extends over 3 inches into included timber. ^b
Unsound surface defects		Same requirements as for sound defects if they extend into included timber. ^b No limit if they do not.
End defects	Sound	No requirements.
	Unsound	None allowed; log must be sound internally, but will admit 1 shake not to exceed $\frac{1}{4}$ the scaling diameter and a longitudinal split not extending over 5 inches into the contained timber.

^a These specifications are minimum for the class. If, from a group of logs, factory logs are selected first, thus leaving only non-factory logs from which to select construction logs, then the quality range of the construction logs so selected is limited, and the class may be considered a grade. If selection for construction logs is given first priority, then it may be necessary to subdivide the class into grades.

^b Included timber is always square, and dimension is judged from small end.

tion of log defects, straightness, and soundness of heart (table 1). Many logs that fall into this class do not meet the requirements for the factory-lumber class, but are well suited for ties and heavy structural timbers. Sound, straight, small-knotted factory-lumber logs will also meet these specifications. Examples of typical structural-class logs are presented in figure 15.

For grading purposes it is considered that the log contains a square timber, the dimensions of which are governed by the small end. Holes are allowed if their depth does not exceed 5 inches from the log surface. Table 3 shows allowable knot size (one-quarter width of face) for the largest squared timber obtainable by log diameters; log knot size (one-third log diameter at point of occurrence) for corresponding log;

maximum sweep allowed per 8 feet of length; and the largest timbers obtainable from a given log, including squared and other commonly stocked dimension timbers.

Larger knots could be allowed where dimension timbers other than squares are to be made, but knot diameter cannot exceed one-quarter of the width of the face of the tie or timber on which it occurs. Where it is definite that logs are to be used for ties, knots up to one-half the diameter of the log at point of occurrence are allowable when they are within 12 inches of either end of the log. This exception cannot be applied to standing timber.

Table 3 will also be helpful in estimating the products obtainable from construction logs, and in relating log character to products.

Figure 15.—Examples of hardwood construction lumber logs.



A 10-foot log 18 inches in diameter at the small end. The cuttings on at least two of the four faces are not equal to the minimum required for factory grade 3. Although it has numerous knots, none has a knot collar exceeding $\frac{1}{3}$ of the log diameter at the point where it occurs. The log contains no rot, shake, or splits, and it is straight.

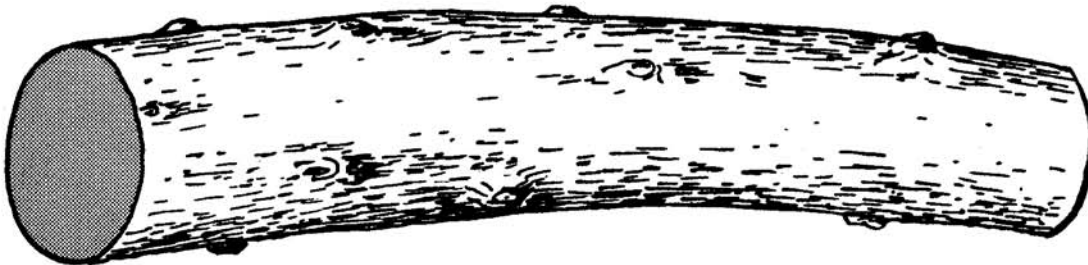

A 12-foot log, 22 inches in diameter at the small end. The cuttings on at least two of the four faces are not equal to the minimum required for a factory grade 3. The numerous knots are small and, although the log is sweepy, the actual sweep does not exceed $\frac{1}{4}$ of the diameter of the small end of the log. There is no rot, shake, or split.

Table 3.—Relationship of log diameter to maximum timber sizes and allowable knot size, in inches

Log d.i.b. small end (inches)	Average diameter of largest knot allowed on log surface		Maximum sweep or crook per 8 feet (absolute)	Largest timber obtainable (rough, green)				
	Largest squared timber	Log		Squared		Common dimension		
				To nearest ¼ inch	To nearest inch			
8	1-7/16	2-2/3	2	5-3/4	6x6 ^a	—	—	—
9	1-5/8	3	2-1/4	*6-1/2	6x6	4x8	6x7 ^b	—
10	1-3/4	3-1/3	2-1/2	7	7x7	6x8 ^c	—	—
11	1-15/16	3-2/3	2-3/4	7-3/4	8x8	4x10	7x8 ^d	7x9 ^e
12	2-1/8	4	3	*8-1/2	8x8	6x10	7x10 ^f	—
13	2-5/16	4-1/3	3-1/4	9-1/4	9x9	8x10	—	—
14	2-1/2	4-2/3	3-1/2	10	10x10	8x12	—	—
15	2-5/8	5	3-3/4	10-3/4	11x11	9x12	—	—
16	2-13/16	5-1/3	4	11-1/4	11x11	6x15	8x14	10x12
17	3	5-2/3	4-1/4	12	12x12	7x16	8x15	9x14
18	3-3/16	6	4-1/2	12-3/4	13x13	8x16	12x14	—
19	3-3/8	6-1/3	4-3/4	*13-1/2	13x13	10x14	6x16	—
20	3-9/16	6-2/3	5	14-1/4	14x14	12x16	—	—
22	3-7/8	7-1/3	5-1/2	*15-1/2	15x15	12x18	14x16	—
24	4-1/4	8	6	17	17x17	14x20	16x18	—
26	4-5/8	8-2/3	6-1/2	*18-1/2	18x18	14x22	16x20	—
28	4-15/16	9-1/3	7	19-3/4	20x20	14x24	18x22	—
30	5-1/4	10	7-1/2	21-1/4	21x21	14x26	16x24	—
32	5-11/16	10-2/3	8	22-3/4	23x23	16x28	18x26	—

^a Class 1 cross-tie.

^b Class 2 cross-tie.

^c Class 3 cross-tie.

^d Class 4 cross-tie.

^e Class 5 cross-tie.

^f Class 6 cross-tie.

* 1/2-inch variation allowed for mismanufacture; i.e., 15-1/2 = 15 x 15 or 16 x 16.

Figure 16.—Suggested specifications for hardwood local-use logs.

Position in tree	Butt and upper
Min. diameter, small end	8 inches +
Min. length, without trim	8 feet +
Sweep allowance, absolute	½ diameter of small end
Max. scale deduction allowed	⅔
Clear cuttings	No requirements
Sound or unsound surface defect limitations	Only requirement is that diameter of knots, holes, rot, etc. shall not exceed ½ diameter of log at point of occurrence.
Sound end defects	No requirements

HARDWOOD LOCAL-USE LOG CLASS

The standard minimum log as suggested by the Forest Service system is defined in the specifications for miscellaneous or local-use class

logs (fig. 16). Examples are presented in figure 17. Although this standard minimum log may vary with species, locality, and economic conditions, its definition is essential to provide a floor.

Figure 17.—Examples of local-use class logs.

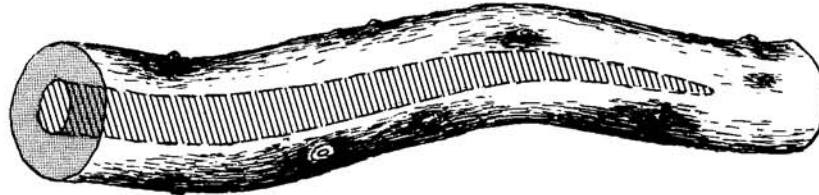

A 14-foot log 16 inches in diameter at the small end. It does not have minimum cuttings required for a factory log. It is too crooked and unsound to meet construction specifications. Sweep and rot deductions are less than 67 percent.

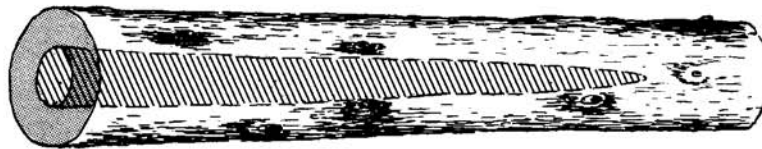

A 12-foot log 18 inches in diameter at the small end. It does not have the cuttings required for a factory log. It has no large knots and no sweep, but it has an unsound heart for which scale deductions will be less than 67 percent.

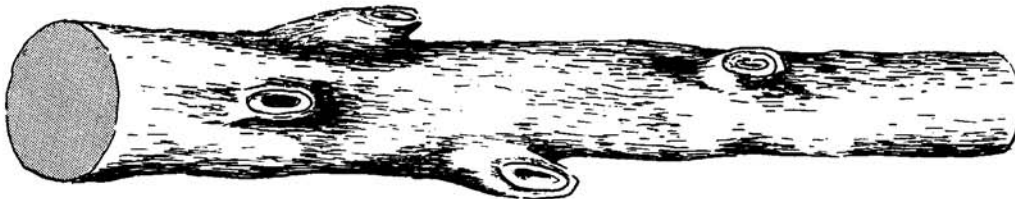

A 16-foot log 18 inches in diameter at the small end. It does not have the cuttings required for a factory log. Although it is sound, several knots are too large for the construction class.



A 16-foot log 20 inches in diameter at the small end. It does not have the cuttings required for a factory grade 3 log because of the deep spiral seams. It will not qualify as a construction log because of unsound heart.

GENERAL GRADING PROCEDURES

Scaling

Scaling a log is the first step in grading. It not only gives an estimate of the content (table 4), but also gives some of the data needed to apply grade specifications. Scaling should be done carefully, according to standard practices that conform to those used in developing the grading rules. For hardwood sawlogs these are:

Diameter measurement: Average small end, inside bark.

Length measurement: Longest included full foot.

Scaling deductions:

1. *Interior deductions.*—the revised scaling practice developed by Grosenbaugh (4) at the Southern Forest Experiment Station works as follows (rule 5, fig. 18 and Appendix II):

- (1) Enclose defect in circle or ellipse (say, 7 inches x 9 inches on a 20-inch log).
- (2) Measure short and long axis of circle or ellipse in inches and add 1 inch to each measurement (8 inches x 10 inches).
- (3) Determine, for each augmented axis, what percentage it is of log diameter in inches minus 1, and round off to nearest 10 percent ($8/19 = 40$ percent, $10/19 = 50$ percent).
- (4) Determine length of defect as percentage of log length (say, $1/4$ or 25 percent).
- (5) Multiply long axis percentage, short axis percentage, and length percentage together; the result is the percentage deduction ($40 \times 50 \times 25 = 5$ percent).

2. *Other deductions.*—Grosenbaugh's rules (rules 1-4, fig. 18) cover these. In determining sweep the number subtracted from actual

Table 4.—International 1/4-inch log rule^a

Diameter (inches)	Volume (board feet) according to length, in feet—												
	8	9	10	11	12	13	14	15	16	17	18	19	20
8	15	20	20	25	25	30	35	35	40	40	45	50	50
9	20	25	30	30	35	40	45	45	50	55	60	65	70
10	30	35	35	40	45	50	55	60	65	70	75	80	85
11	35	40	45	50	55	65	70	75	80	85	95	100	105
12	45	50	55	65	70	75	85	90	95	105	110	120	125
13	55	60	70	75	85	90	100	105	115	125	135	140	150
14	65	70	80	90	100	105	115	125	135	145	155	165	175
15	75	85	95	105	115	125	135	145	160	170	180	195	205
16	85	95	110	120	130	145	155	170	180	195	205	220	235
17	95	110	125	135	150	165	180	190	205	220	235	250	265
18	110	125	140	155	170	185	200	215	230	250	265	280	300
19	125	140	155	175	190	205	225	245	260	280	300	315	335
20	135	155	175	195	210	230	250	270	290	310	330	350	370
21	155	175	195	215	235	255	280	300	320	345	365	390	410
22	170	190	215	235	260	285	305	330	355	380	405	430	455
23	185	210	235	260	285	310	335	360	390	415	445	470	495
24	205	230	255	285	310	340	370	395	425	455	485	515	545
25	220	250	280	310	340	370	400	430	460	495	525	560	590
26	240	275	305	335	370	400	435	470	500	535	570	605	640
27	260	295	330	365	400	435	470	505	540	580	615	655	690
28	280	320	355	395	430	470	510	545	585	625	665	705	745
29	305	345	385	425	465	505	545	590	630	670	715	755	800
30	325	370	410	455	495	540	585	630	675	720	765	810	860
31	350	395	440	485	530	580	625	675	720	770	820	870	915
32	375	420	470	520	570	620	670	720	770	825	875	925	980
33	400	450	500	555	605	660	715	765	820	875	930	985	1,045
34	425	480	535	590	645	700	760	815	875	930	990	1,050	1,110
35	450	510	565	625	685	745	805	865	925	990	1,050	1,115	1,175

^a Values as published by H. H. Chapman, extended by formula: $V = (0.22D^2 - 0.71D) \times .905$ for 4-foot section. Taper allowance: $1/2$ inch per 4 feet lineal.

Figure 18.—Methods of determining scaling deduction.
(Examples based on a 16-foot log with 20-inch scaling diameter)

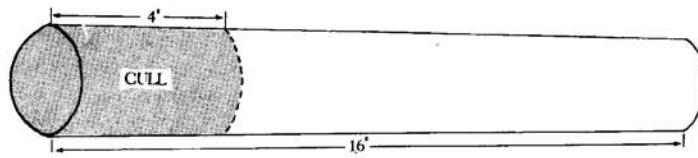

Defect section (rule 1):
 Percent deduction = $\frac{4}{16} = 25\%$

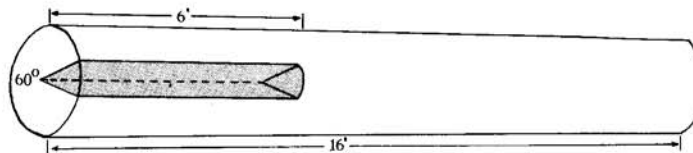

Defect section (rule 2):
 Percent deduction = $\left(\frac{6}{16}\right) \left(\frac{60}{360}\right) = 6-1/4\%$

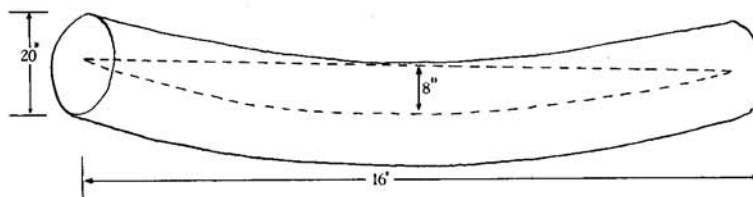

Sweep (rule 3):
 Percent deduction = $\frac{8-2}{20} = 30\%$

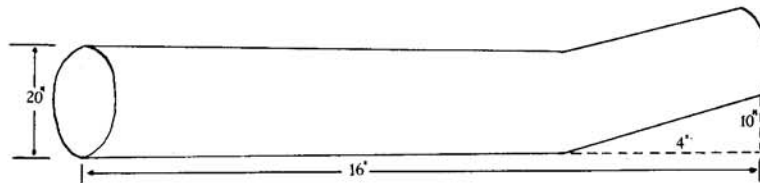

Crook (rule 4):
 Percent deduction = $\left(\frac{10}{20}\right) \left(\frac{4}{16}\right) = 12-1/2\%$

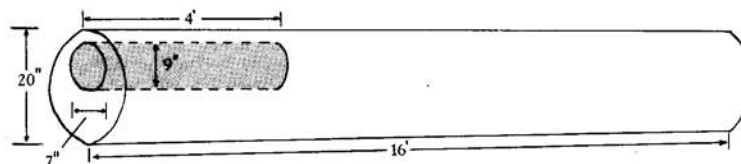

Interior defect (rule 5):
 Percent deduction = $\frac{(8)(10)}{(20-1)^2} \times \frac{4}{16} = 5-5/9\%$
 In practice each ellipse axis can be divided by $(20-1)$
 and rounded to nearest tenth if desired.
 Thus $\frac{8}{19} = .4$, $\frac{10}{19} = .5$, and $(.4)(.5) \left(\frac{4}{16}\right) = 5\%$

From: Grosenbaugh, L. R., SHORT CUTS FOR CRUISERS AND SCALERS, USDA Forest Serv. South. Forest Exp. Sta., Occas. Paper 126, 1952.

sweep depends on log length as follows:⁵ 8 feet thru 10 feet — 1, 11 feet thru 13 feet — 1½, and 14 feet thru 16 feet — 2.

Relation of Scaling Deductions to Log-Grading Defects

In general, making a scaling deduction from the scale of a log up to the limits indicated in

the grading rules does not upgrade the log, even though in some cases it may appear that the existence of a rotten heart center, for which scaling deduction is made, would raise the average grade of usable lumber produced. Parts of the portion for which deduction is made may or may not affect clear cutting areas. If they do, they are individual log grade defects.

⁵ See Table 5 for sweep deduction percentages.

Table 5.—Sweep deduction from gross scale by length and diameter (in percent; based on rule 3)

Absolute sweep in inches		Scaling diameter, average small end inside bark, in inches											
8-9-10 foot logs	14-15-16 foot logs	8	10	12	14	16	18	20	22	24	26	28	30
—	3	12	10	8	7	6	6	5	5	4	4	4	3
3	4	25	20	17	14	12	11	10	9	8	8	7	7
4	5	38	30	25	21	19	17	15	14	12	12	11	10
5	6	50	40	33	29	25	22	20	18	17	15	14	13
6	7	62	50	42	36	31	28	25	23	21	19	18	17
7	8	—	60	50	43	38	33	30	27	25	23	21	20
8	9	—	—	58	50	44	39	35	32	29	27	25	23
9	10	—	—	67	57	50	44	40	36	33	31	29	27
10	11	—	—	—	64	56	50	45	41	38	35	32	30
11	12	—	—	—	—	62	56	50	45	42	38	36	33
12	13	—	—	—	—	—	61	55	50	46	42	39	37
13	14	—	—	—	—	—	—	60	54	50	46	43	40
14	15	—	—	—	—	—	—	65	59	54	50	46	43
15	16	—	—	—	—	—	—	—	64	58	54	50	47
16	17	—	—	—	—	—	—	—	—	62	58	54	50
17	18	—	—	—	—	—	—	—	—	—	62	57	53
18	19	—	—	—	—	—	—	—	—	—	65	61	57
19	20	—	—	—	—	—	—	—	—	—	—	64	60
20	21	—	—	—	—	—	—	—	—	—	—	—	63
21	22	—	—	—	—	—	—	—	—	—	—	—	67
11-12-13 foot logs													
3		19	15	12	11	9	8	8	7	6	6	5	5
4		31	25	21	18	16	14	12	11	10	10	9	8
5		44	35	29	25	22	19	18	16	15	13	12	12
6		56	45	38	32	28	25	22	20	19	17	16	15
7		—	55	46	39	34	31	28	25	23	21	20	18
8		—	65	54	46	41	36	32	30	27	25	23	22
9		—	—	62	54	47	42	38	34	31	29	27	25
10		—	—	—	61	53	47	42	39	35	33	30	28
11		—	—	—	—	59	53	48	43	40	37	34	32
12		—	—	—	—	66	58	52	48	44	40	38	35
13		—	—	—	—	—	64	58	52	48	44	41	38
14		—	—	—	—	—	—	62	57	52	48	45	42
15		—	—	—	—	—	—	—	61	56	52	48	45
16		—	—	—	—	—	—	—	66	60	56	52	48
17		—	—	—	—	—	—	—	—	65	60	55	52
18		—	—	—	—	—	—	—	—	—	63	59	55
19		—	—	—	—	—	—	—	—	—	67	62	58
20		—	—	—	—	—	—	—	—	—	—	66	62
21		—	—	—	—	—	—	—	—	—	—	—	65

Note: For odd lengths and half inches of sweep, deductions can be interpolated from the figures given.

Hardwood Tree Grades for Factory Lumber

The U.S. Forest Service Hardwood Tree Grades for Factory Lumber were developed for use on standing sawtimber (4a). The tree grade specifications are accompanied by dry lumber grade yields for 11 species: yellow birch, paper birch, red maple, sugar maple, yellow-poplar, black cherry, basswood, northern red oak, black oak, white oak, and chestnut oak. Lumber grade yields are also available for graded aspen trees (4b).

By applying these tree grades to a stand of timber, you can divide the trees into three groups, each with its own set of lumber grade yields. You can then predict the volume and value of lumber that can be sawed from the graded trees.

A tree's grade is related to the grade of the butt log. The sections of this guide that pertain to evaluating the surface features of factory logs should be consulted when grading trees.

Selected References

1. American Railway Engineering Association. 1970. A.R.E.A. MANUAL FOR RAILWAY ENGINEERING. Chap. 3—Ties. Chicago, Ill. 42 p.
2. Carpenter, R. D. 1967. MAJOR DEFECTS IN SOUTHERN HARDWOOD VENEER LOGS AND BOLTS. South. Lumberman 214 (2668):18.
3. Flick, Frances J., Nellie G. Larson, and Marcia J. Sigler. 1961. GRADING OF LOGS AND TREES FOR QUALITY: BIBLIOGRAPHIES COMPILED FOR THE FOREST SERVICE LOG GRADING COMMITTEE. USDA For. Serv., Washington, D.C. 50 p.
4. Grosenbaugh, L. R. 1952. SHORTCUTS FOR CRUISERS AND SCALERS. USDA For. Serv. South. For. Exp. Stn. Occas. Pap. 126. 24 p.
- 4A. Hanks, Leland F. 1976. HARDWOOD TREE GRADES FOR FACTORY LUMBER. USDA For. Serv. Res. Pap. NE-333. 81 p.
- 4B. Hanks, Leland F., and Robert L. Brisbin. 1978. LUMBER GRADE YIELDS FOR GRADED ASPEN LOGS AND TREES. USDA For. Serv. Res. Pap. NE-423. 13 p.
5. Harrar, E. S., and R. A. Campbell. 1966. THE MAJOR DEFECTS IN SOUTHERN HARDWOOD VENEER LOGS AND BOLTS. USDA For. Serv. Res. Pap. SE-19. 23 p.
6. Henley, J. W. 1961. OVERRUN ESTIMATES OF THE SCRIBNER DECIMAL C LOG RULE AND THE INTERNATIONAL 1/4-INCH LOG RULE FOR HARDWOOD LOGS. USDA For. Serv. For. Prod. Lab. Rep. 2214. 4 p. + 68 tables.
7. Lockard, C. R., J. A. Putnam, and R. D. Carpenter. 1963. GRADE DEFECTS IN HARDWOOD TIMBER AND LOGS. U.S. Dep. Agric., Agric. Handb. 244. 39 p.
8. Lockard, C. R., J. A. Putnam, and R. D. Carpenter. 1950. LOG DEFECTS IN SOUTHERN HARDWOODS. U.S. Dep. Agric., Agric. Handb. 4. 37 p.
9. National Hardwood Lumber Association. 1971. RULES FOR THE MEASUREMENT AND INSPECTION OF HARDWOOD AND CYPRESS LUMBER. Chicago, Ill. 116 p.
10. Newport, Carl A., C. R. Lockard, and C. L. Vaughan. 1959. LOG AND TREE GRADING AS A MEANS OF MEASURING QUALITY. Natl. Log Grade Comm., USDA For. Serv., Washington, D.C. 31 p.
11. Putnam, John A., G. M. Furnival, and J. S. McKnight. 1960. MANAGEMENT AND INVENTORY OF SOUTHERN HARDWOODS. U.S. Dep. Agric., Agric. Handb. 181. 102 p.
12. U.S. Forest Service. 1964. CHANGES IN MILL RUN HARDWOOD SAWLOG LUMBER GRADE YIELDS WHEN VENEER LOGS ARE WITHDRAWN. USDA For. Serv. Res. Pap. FPL-13. 134 p.
13. U.S. Forest Service. 1966. HARDWOOD LOG GRADES FOR STANDARD LUMBER. USDA For. Serv. Res. Pap. FPL-63. 52 p.

Appendix I

HOW TO USE LOG-GRADE INFORMATION TO ESTABLISH LOG VALUES

Factory-Lumber Logs

Log grades accompanied by lumber grade yields provide the information needed for value determination. U.S. Forest Service Research Paper FPL-63 presents lumber grade yield information by log grade and diameter for several hardwood species. Log overruns and lumber thickness distributions are also covered in the report. One method of obtaining log value is outlined below.

- I. To determine value per Mbf.
 - a. For each log grade-diameter class apply the percent yields to the lumber tally as shown.
 - b. Apportion the resulting lumber grade volumes into the various thickness classes using either the tabular thickness distribution or one better suited to the situation.
 - c. Apply current lumber prices, published or local, to these lumber grade thickness volumes, and obtain total lumber value.
 - d. Divide this value by total lumber tally; the result is value per Mbf for the log grade-diameter class in question.
- II. To determine log volume.
 - a. Obtain net scale of a log.
 - b. Estimate lumber volume by applying appropriate overrun to net log scale.
- III. To determine log value.
 - a. Multiply the estimated lumber volume by the value per Mbf and divide the product by 1,000.

This method of value determination predicts the value of lumber that can be sawed from a log with good sawing practice in a well maintained mill. Differences between actual and predicted values will be quite high for single logs, but will decrease as the number of logs increases. We suggest that 20 logs is the minimum number for which consistent results should be expected.

The following sources of lumber price information should be consulted:

NATIONAL HARDWOOD MAGAZINE, 2029 Peabody Ave., Memphis, Tenn. Prices of southern Appalachian and northern hardwoods, f.o.b. Chicago, are published each month.

HARDWOOD MARKET REPORT, P. O. Box 4042, 28 N. Cleveland, Memphis, Tenn. Prices are published weekly for southern hardwoods, f.o.b. mills in Texas and Louisiana; for Appalachian hardwoods, f.o.b. mills in the Johnson City, Tenn., area; and for northern hardwoods, f.o.b. mills in the Wausau, Wis., area.

COMMERCIAL BULLETIN, Curtis Guild & Co., 88 Broad St., Boston, Mass. New England hardwood and softwood prices are published weekly.

For construction and local-use logs, no graded product information is available. Values must be developed from individual mill experience. The National Hardwood Lumber Association's Rules for the Measurement and Inspection of Hardwood and Cypress Lumber should be consulted for information about other products.

Appendix II

TABLES FOR MAKING INTERIOR SCALE DEDUCTIONS

These two working tables of factors for determining scale deduction are based on Grosenbaugh's Rule 5.

Table 6.—Factors given in this table express the relation of scaling diameter minus 1 (in inches, average d.i.b. of small end) and length of scaling defect section (as estimated to the nearest 10 percent of log length). *Use actual diameter, do not take off an inch.*

Table 7.—This table shows factors that evaluate the cross section of the defect area. *Actual long and short dimensions in inches are used; do not add a collar allowance in measuring.*

To find scale deduction:

1. In Table 6, find factor for log scaling diameter (inches) and length of scaling defect section (percent of log length), i.e., for an 18-inch log with a scaling defect section 30 percent of its length the factor is 0.6.
2. In Table 7, find factor for short and long dimension of defect cross section (i.e., 5 inches x 7 inches = factor 8).
3. Multiply the two factors to get scale deduction in percent of log scale: $8 \times 0.6 = 4.8$ percent. Round to nearest percent = 5 percent.

If this procedure seems cumbersome, consider the sequence. Log length, scaling diameter, and scaling-defect section length can be determined in one operation; cross-section dimensions in another. As the first two (length and diameter) are recorded, the table 6 factor for defect length can be observed and kept in mind. Then, after the cross section is measured, the appropriate factor can be located in table 7 and the two factors can be multiplied mentally.

For logs over 25 inches in scaling diameter, use Grosenbaugh's Rule 5, page 25.

Where cull area goes completely through the log, use the average of dimensions measured on both ends.

Where defect cross-section can be contained in a rectangle instead of an oval, multiply chart values by $5/4$.

Table 6.—Scaling diameter: defect length factors

Scaling diameter inches	Percent of log length in cull section									
	10	20	30	40	50	60	70	80	90	100
8	1.2	2.4	3.5	4.7	5.9	7.1	8.2	9.4	10.6	11.8
9	.9	1.8	2.7	3.6	4.5	5.4	6.3	7.2	8.1	9.0
10	.7	1.4	2.1	2.8	3.6	4.3	5.0	5.7	6.4	7.1
11	.6	1.1	1.7	2.3	2.9	3.4	4.0	4.6	5.2	5.8
12	.5	1.0	1.4	1.9	2.4	2.9	3.3	3.8	4.3	4.8
13	.4	.8	1.2	1.6	2.0	2.4	2.8	3.2	3.6	4.0
14	.3	.7	1.0	1.4	1.7	2.0	2.4	2.7	3.1	3.4
15	.3	.6	.9	1.2	1.5	1.8	2.1	2.4	2.6	2.9
16	.3	.5	.8	1.0	1.3	1.5	1.8	2.0	2.3	2.6
17	.3	.4	.7	.9	1.1	1.4	1.6	1.8	2.0	2.3
18	.2	.4	.6	.8	1.0	1.2	1.4	1.5	1.8	2.0
19	.2	.4	.5	.7	.9	1.1	1.2	1.4	1.6	1.8
20	.2	.3	.5	.6	.8	1.0	1.1	1.3	1.4	1.6
21	.2	.3	.4	.6	.7	.9	1.0	1.2	1.3	1.4
22	.1	.3	.4	.5	.7	.8	.9	1.0	1.2	1.3
23	.1	.2	.4	.5	.6	.7	.8	1.0	1.1	1.2
24	.1	.2	.3	.4	.5	.6	.8	.9	1.0	1.1
25	.1	.2	.3	.4	.5	.6	.7	.8	.9	1.0

Note: Do not take off an inch in measuring diameter.

Table 7.—Interior defect cross-section factors

Short axis, inches	Long axis, inches													
	2	3	4	5	6	7	8	9	10	11	12	13	14	15
2	2	2	3	3	4	4	5	5	6	6	7	7	8	8
3	—	3	3	4	5	5	6	7	8	8	9	10	10	11
4	—	—	4	5	6	7	8	9	10	10	11	12	13	14
5	—	—	—	6	7	8	9	10	11	12	14	15	16	17
6	—	—	—	—	8	10	11	12	13	15	16	17	18	19
7	—	—	—	—	—	11	12	14	15	17	18	19	21	22
8	—	—	—	—	—	—	14	16	17	19	20	22	23	25
9	—	—	—	—	—	—	—	17	19	21	23	24	26	28
10	—	—	—	—	—	—	—	—	21	23	25	27	29	31
11	—	—	—	—	—	—	—	—	—	25	27	29	31	33
12	—	—	—	—	—	—	—	—	—	—	29	32	34	36
13	—	—	—	—	—	—	—	—	—	—	—	34	36	39
14	—	—	—	—	—	—	—	—	—	—	—	—	39	42
15	—	—	—	—	—	—	—	—	—	—	—	—	—	44
16	—	—	—	—	—	—	—	—	—	—	—	—	—	—
17	—	—	—	—	—	—	—	—	—	—	—	—	—	—
18	—	—	—	—	—	—	—	—	—	—	—	—	—	—

Note: Do not add a collar allowance in measuring axes.



THE FOREST SERVICE of the U. S. Department of Agriculture is dedicated to the principle of multiple use management of the Nation's forest resources for sustained yields of wood, water, forage, wildlife, and recreation. Through forestry research, cooperation with the States and private forest owners, and management of the National Forests and National Grasslands, it strives — as directed by Congress — to provide increasingly greater service to a growing Nation.